

Contents

What in the box	2
How to mount the lifting magnet	2
Introductions	3
Dimensions and Weights	3
Lifting Capacities	3
Safe Operation Rules	4
Estimation of Reduction of the Rated Max. Lifting Capacity	5
■ Flat Load	6
■ Round Solid Bar	6
■ Pipe	6
■ Surface Conditions	7
■ Materials of load	7
■ Load and Ambient Temperature	7
■ Examples of Estimation of Lifting Capacity	7
Operation Procedure	7
Pretest lifting capacity	8
Inspection, Maintenance and Repair	8
Recommended Applications	8
Carbon Steel Weight Chart	9



Caution:

Read this book carefully and obey its instructions strictly. Failure to do so could result in property damage and personal injury or death.

If you have any questions about the use of the lifting magnets. stop the lifting operation and email to info@armsmag.com or call 360 647 8438.

Instruction Manual of Permanent Lifting Magnets

NL-330B, NL-660B, NL-1320B, NL-2200B, NL-4400B

Armstrong LiftMag™



Your lifting operation will be efficient and safe by using Armstrong LiftMag™, if you fully understand and strictly obey the instructions and rules stated in this book.

The content in the box

Open the wooden box by cutting off the plastic straps which wrap around the box and taking off the nails at the top of the box.

You will find:

- 1) 1 Main body of the lifting magnet.
- 2) 1 Handle.
- 3) 1 Screw for fixing the handle to the shaft of the rotator at the main body.
- 4) 1 screw driver or inner hexagon spanner.
- 5) Test Report of the breakaway force of the lifting magnet in the box.
- 6) This book.

To mount the handle to the main body of the lifting magnet

- 1) Insert the tip of the screw driver included in the box into the small hole at the round surface of the shaft end and turn the shaft until the big hole at the shaft end is visible.
- 2) Put the handle into the big hole, let the tap hole at the handle end be seen through the hole at the flat surface of the shaft end.
- 3) Insert the screw through the hole at the flat surface of the shaft and tighten it into the tap hole at the handle end by using the screw driver.

Now, the lifting magnet is ready for operation.



Warning:

However, you are not ready to use it until you carefully read and completely understand this book!

NL-330B, 660B, 1320B, 2200B, 4400B Instruction Manual

Please read and understand this Instruction Manual before using the lifting magnets.

Introductions

NL-B series permanent lifting magnets using Neodymium magnets are designed and made for holding, carrying and releasing flat or round ferrous parts without any electrical power supply. They attract ferrous parts by turning its handle counterclockwise to "On" position and release the parts at "Off" position. For more safety, a special device (Slide Pin) locks the handle at "On" position and keeps the lifter having lift power until operator unlocks it.

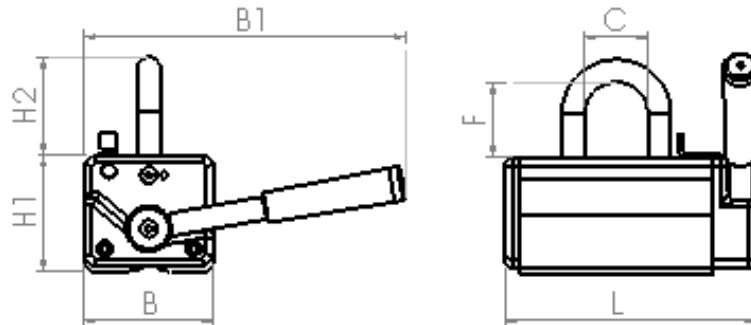

Dimensions:
Chart 1: Dimensions and Weight

P/N	Model	Overall Size					Eye Opening		Weight (lb)
		L (in)	B (in)	H1 (in)	H2 (in)	B1 (in)	F (in)	C (in)	
81503	NL-330B	5.1	2.4	2.4	2.2	6.5	1.7	1.50	6
81506	NL-660B	5.9	3.5	3.50	3.2	9.1	1.9	1.7	19
81513	NL-1320B	8.7	4.4	3.9	3.1	10.5	2.4	2.0	38
81522	NL-2200B	11.2	5.7	5.0	3.4	12.4	2.5	2.4	73
81544	NL-4400B	15.7	6.9	5.8	5.0	15.4	3.8	2.7	165

Chart 2: Rated Max. Lifting Capacity and Max. Working Temperature

P/N	Model	To lift Flat Load Lifting				To lift Round load			Max. Working Temp. (F°)
		Rated Max. Cpcty (lb)	Test Load (lb)	Min. thk to get the Rated Max. Cpcty (in)	Min. thk of load to lift (in)	Rated Max. Capacity (lb)	Max. Dia. (in)	Min. thk of pipe wall to lift (in)	
81503	NL-330B	330	990	0.591	1/4	132	6	1/4	148
81506	NL-660B	660	1,980	0.787	1/4	264	8	1/4	148
81513	NL-1320B	1,320	3,690	1.181	1/2	528	10	3/8	148
81522	NL-2200B	2,200	6,600	1.575	3/4	880	12	1/2	148
81544	NL-4400B	4,400	13,200	2.165	1	No	No	No	148



How to get the Rated Max. Lifting Value?

The Rated Max. Lifting Capacity for each model in Chart 2 could be reached only if:

- The load has flat, smooth and clean surface, $R_a < 6.3\mu\text{m}$.
- The thickness of the load is thicker than the “Min. thickness to get the Rated Max. Capacity”, that is shown in Chart 2.
- Not exceed the maximum size and length. (See details in chart 3.)
- Low Carbon Steel, similar to AISI 1020.
- Working temperature is less than 90°F.

Safety Pre-Testing

In some complicated lifting situations it is difficult to determine that a lift is safe or not. This lifting magnet can pre-test the safety of the lift operation. (See page 9.)

Safe Operation Rules:



Warning:

Safety when using lifting magnet is exclusively the responsibility of the operator!

Accidents can happen at any time when a heavy work load is being lifted, hung and moved by lifting magnets, especially when not obeying the strict operation rules, or operating the devices that have not been inspected before use.

Any dropping of heavy work load would result in personal injury or even death as well as property damage. The following Safety Operation Rules must be kept in mind and observed in operating the lifting magnets.

- Never allow any unauthorized personnel to operate the lifting magnets.
- Never use the lifting magnet before inspecting it.
- Always be confident that any lifting must have 3:1 safety factor.
- Stay clear of the work load any time.
- Warn all personnel in the site before you are going to lift a work load.
- No vibration of or impact to the lifting magnet in transportation.
- Never move the lifting magnet and load over or close to personnel.
- Prohibit any personnel close to, stand or pass under the magnet.
- Always pay your close attention until the load has been landed.
- Never operate the lifting magnet higher than 148°F.

There are some more safety instructions, reminds and experiences:

- Make load surface clean. Remove dust, burrs, unnecessary paints and chips from it.
- In most situations the lifting magnets don't reach their “Rated Max. Lifting Capacity” in chart 2. See the “Estimation of Reduction of the Max. capacity” at page 5, 6,7 and 8.
- Don't turn the handle without any load underneath. It should damage the lifting magnet.
- Load must stay in level during lifting.
- Use a spreader bar hanging two or more lifting magnets to lift big plate.
- If it is hard to turn the handle from “Off” to “On” position, the load could be too thin, or the air gap between the load and the lifting magnet could be too big. Turn the handle in an extremely hard manner could damage the lifting magnet.
- Never lift more than one sheet at a time.
- always gently and smoothly lift, move and lay down the lifting magnet and load without sudden acceleration and deceleration.

Estimation of Reduction of the Rated Max. Lifting Capacity:



Attention

First, but most important, estimate the reduction of the rated max. lifting capacity before you are about to lift a load.

1) Thickness, size and length of flat load:

When load thickness is less than the “Min. Thickness to get the Rated Max. Capacity” in Chart 2, a part of the magnetic flux will penetrate the load and disperse into the air. Therefore the holding force will be less.

When size, or length is great, a warp of plate/bar/tube could be created. In this situation, an air gap around the edges of the lifting magnet takes place. So the pull will decrease; more seriously, the plate, bar or tube could peel off and drop.

Please see Chart 3 below.

Chart 3: Lifting Capacities for Flat Loads with different thicknesses

Model	Lifting Conditions		Thickness of Flat Load								
			1/4"	3/8"	1/2"	3/4"	1"	1-1/2"	2"	3"	4"+
NL-330B	Rated Capacity (lb)		80	130	220	330	330	330	330	330	330
	To Lift Plate Only	Rated Capty (lb)	60	100	200	330	330	330	330	330	330
		Max. Size (s. f.)	6	6	7	7	5	3.5	2.6	1.7	1.3
		Max. Length (ft.)	3	3	3	3	3	2	2	2	2
NL-660B	Rated Capacity (lb)		200	300	400	500	660	660	660	660	660
	To Lift Plate Only	Rated Capty (lb)	130	220	315	430	500	660	660	660	660
		Max. Size (s. f.)	12	14	15	13	12	10.5	7.9	5.2	3.9
		Max. Length (ft.)	4	4	4	4	5	5	5	6	6
NL-1320B	Rated Capacity (lb)		No	No	650	900	1,100	1,320	1,320	1,320	1,320
	To Lift Plate Only	Rated Cpcty (lb)	No	No	360	620	900	1,320	1,320	1,320	1,320
		Max. Size (s. f.)	No	No	17	20	21.4	21	15.7	10.5	7.9
		Max. Length (ft.)	No	No	5	5	6	6	6	6	6
NL-2200B	Rated Capacity (lb)		No	No	No	1,200	1,500	2,200	2,200	2,200	2,200
	To Lift Plate Only	Rated Cpcty (lb)	No	No	No	900	1,200	1,500	2,000	2,200	2,200
		Max. Size (s. f.)	No	No	No	27	28	24	24	17.5	13
		Max. Length (ft.)	No	No	No	6	6	6	6	7	7
NL-4400B	Rated Capacity (lb)		No	No	No	No	2,400	3,000	4,000	4,400	4,400
	To Lift Plate Only	Rated Cpcty (lb)	No	No	No	No	1,500	2,200	2,800	4,000	4,400
		Max. Size (s. f.)	No	No	No	No	36	35	33	32	26
		Max. Length (ft.)	No	No	No	No	8	8	8	8	8

2) Round Solid Bar and pipe:

Because a round load can only touch “V” shaped slot at the bottom of lifting magnet at two points, the magnetic flux will hardly enter the load from the magnet. Furthermore, if the load is a pipe, some of magnetic flux will penetrate its wall and go into air that causes additional flux loss.

Please look at Chart 4 and 5 to see how the pull decreases:

Chart 4: Lifting Capacities for Solid Bars with different diameters

Diameter of Solid Bar		2"	3"	4"	5"	6"	8"	10"	12"
NL-330B	Max. Capacity (lb)	70	120	120	120	120	---	---	---
	Max. Length (ft)	4	8	8	8	8	---	---	---
NL-660B	Max. Capacity (lb)	107	216	264	264	264	264	---	---
	Max. Length (ft)	10	9	7.7	5	3.4	1.9	---	---
NL-1320B	Max. Capacity (lb)	---	264	528	528	528	528	528	---
	Max. Length (ft)	---	11	12	8	5.5	3	2	---
NL-2200B	Max. Capacity (lb)	---	336	600	880	880	880	880	880
	Max. Length (ft)	---	14	14	13	9	5	3.3	2.3
NL-4400B	Not work	---	---	---	---	---	---	---	---

Chart 5: Lifting Capacities for Pipes with different diameters and wall thicknesses

Nom. Size		2.5"			3"	4"	6"		8"		10"		12"				
Overall Diameter		3"			3.5"	4.5"	6.625"	8.625"	10.75"		12.75"						
Pipe wall Thickness		0.276"	0.300"	0.337"	0.280"	0.432"	0.277"	0.322"	0.500"	0.307"	0.365"	0.500"	0.593"	0.330"	0.375"	0.406"	0.500"
NL-330B	Max. Capty (bl)	30	40	45	45	60	---	---	---	---	---	---	---	---	---	---	---
	Max. Length (ft)	2.6	3.2	4	4	5	---	---	---	---	---	---	---	---	---	---	---
NL-660B	Max. Capty (bl)	50	70	85	50	100	50	80	132	---	---	---	---	---	---	---	---
	Max. Length (ft)	6.5	6.8	5.7	2.6	3.5	2	2.8	3	---	---	---	---	---	---	---	---
NL-1320B	Max. Capty (lb)	---	---	---	---	150	---	---	190	---	---	190	320	---	105	130	190
	Max. Length (ft)	---	---	---	---	5.3	---	---	4.4	---	---	3.5	5	---	2.1	2.4	2.9
NL-2200B	Max. Capity (lb)	---	---	---	---	---	---	---	210	---	---	210	250	---	---	---	210
	Max. Length (ft)	---	---	---	---	---	---	---	4.8	---	---	3.8	3.9	---	---	---	3.2
NL-4400B	Not work	---	---	---	---	---	---	---	---	---	---	---	---	---	---	---	---

3) Surface conditions of the load:

If the surface is rough, dirty, painted, not very flat, or has chips, burrs, dents, there will be an air gap between load and lifting magnet. The magnetic flux will meet high resistance through the air gap and consequently the pull force will be greatly decreased.

■ If the surface of the load is rusty, dirty or rough, approximate 0.010" air gap will be created between the lifting magnet and the load. Therefore, the lifting capacity will be 50%-85%.

■ If the surface of the load is painted, very rusty or rough machined, or not very flat, the air gap could be 0.020", the lifting capacity could be only 40%-75%.

Chart 6: The percentages of lifting capacities caused by different air gaps

Model	Air Gap					
	0.0000" (0.0mm)	0.0118" (0.3mm)	0.0197" (0.5mm)	0.0315" (0.8mm)	0.0394" (1.0mm)	0.059" (1.50mm)
NL-330B	100%	75%	70%	50%	45%	30%
NL-660B	100%	74%	61%	46%	42%	27%
NL-1320B	100%	81%	70%	52%	47%	34%
NL-2200B	100%	80%	72%	54%	51%	42%
NL-4400B	100%	77%	67%	50%	48%	37%

4) Materials of the load:

The Rated Max. Lifting Capacity in Chart 2 is for Low Carbon Steel. The more alloy content in the load material, the lower the holding force is.

- Low Carbon Steel: 100%.
- Middle Carbon Steel: 85%-90%.
- High Carbon Steel: 70%-75%.
- Cast Iron: 45%-50%

5) Load and Ambient Temperature:

- Should be between -40°F and 148°F, but
- Maximum capacity at 90°F is 90%.only.
- Maximum capacity at 148°F is 75 %.only.
- Never use lifting magnets over 176°F. Otherwise they will lose their power permanently!

Example 1: Lifting a plate

Use NL-660B to lift a 2" thick middle Carbon steel plate, rough and dirt surface when the room temperature is 90°F.

The lifting capacity will approximately be:

660 lbs (see Chart 3.) x 85% (Middle Carbon steel) x 67% (1/64" air gap estimated) x 90%(working temperature) = 338lbs

Example 2:

Use NL-660B to lift a 4" diameter, low Carbon, solid round bar with a rusty surface. Working temperature is 120°F at that time.

The lifting capacity will approximately be:

264 lbs (see Chart 4.) x 100% (low Carbon steel) x 80% (1/128" air gap at the two touch lines at the "V" shaped slot) x 80%(working temperature) = 169 lbs

Example 3:

Use NL-660B to lift a low Carbon steel pipe of Nom. Size 6", 0.432" wall thick, dirt and rust surface, working temperature is 48 °F.

The lifting capacity will approximately be:

100 lbs (see Chart 5) x 100% (low Carbon steel) x 80% (1/128" estimated air gap at the two touch lines at "V" shaped slot) x 100% (working temperature) = 80 lbs

Operation Procedure:



Warning:

The operator must understand that he will be responsible exclusively for any personal injury or death and any property damage caused by his lifting operation!

Before you operate a lift you must estimate a reduction of Rated Max. Lifting capacity. See page 5,6,7 and 8.

- 1) Take final inspection of the lifting magnet. See details in "Maintenance and Repair"
- 2) Remove dust, chips, burrs from the load surface. Make it as clean as possible.
- 3) Check hook, chain and all other support equipment.
- 4) Warn all people in the site that a lift will begin.
- 5) Place the lifting magnet slowly and gently onto the center of gravity of the load in order to guarantee the load will stay in level during lift and transport.
- 6) Turn the handle from OFF to ON position. **Make sure the slide pin locks the handle at "ON" position.**
- 7) Stay clear of the load and slowly lift it.

- 8) Move the lifting magnet and the load smoothly without any vibration, swinging, sudden acceleration or deceleration, impaction and objection.
- 9) Slowly and gently lay down the load onto the destination, without any impaction.
- 10) Unlock the slide pin and turn the handle back from ON to OFF position.
- 11) Remove the lifting magnet and park it at a safe place.

Safety Pre-Test:

In some complicated situations it is difficult to estimate the actual lifting value with enough safety coefficient and consequently you are not sure if the lifting operation is safe or not, then you can take the following steps to get a safer lifting operation.

1. Place the lifting magnet at the load.
2. Turn the handle counterclockwise to the vertical position.
3. Insert the tip of the screw driver shipped with the lifting magnet into a small hole at the yellow cover to hold the handle in the position.
4. Lift the lifting magnet and the load 2"-3" from the floor.
5. If the load can be lifted, place the load back onto the floor.
6. Take off the screw driver and turn the handle to ON position. The handle is locked by the slide pin.
7. Lift the load again. This time the safety coefficient is 2 at least.



Warning:

Don't continue to lift the load when the handle is still in vertical position. It is dangerous because the safety coefficient is very low in such situation!

Inspection, Maintenance and Repair:

1) Inspection prior to each lift:

- Clean the bottom surface of the lifting magnet. Remove dust, rust, chips, and burrs, if any.
- Check the body, lifting eye for any cracks or distortion. Stop the lift if any damages found.
- Make sure the lifting eye has been fixed to the body in securing tightness. Check and find any loose fasten screws.
- Then slide pin with a spring at the handle should be always extended up to the stop position.
- With a load underneath, the handle could be turned smoothly without mechanical objections.

2) Maintenance when the lifting magnet not in use:

- Protect magnetic poles from rusting with oil after use. Store lifter in an area free of metal chips, grit and moisture.

3) Yearly inspection:

- Test Rated Max. Lifting Capacity by lifting a metal plate in such conditions shown under Chart 2. Armstrong Magnetics has service to test it by using Pull-Off Tester.

Recommended Applications:

Armstrong LiftMag™ is the professional solution to high efficient handling ferrous materials indoor, such as steel plate, forgings, dies and similar parts. They are widely used in machine shops, warehouses, production lines and shipping areas for fast loading, and unloading heavy steel items.

Chart 7: Carbon Steel Weight

Plate		Round Solid Bar	
Thickness (in)	Weight per S.F. (lb)	Diameter (in)	Weight per F. (lb)
1/4	10.5	3	24
3/8	15.75	4	42.7
1/2	21	5	66.8
3/4	31.5	6	96.2
1	42	7	130.9
1-1/2	63	8	171
2	84	9	216.5
2-1/2	105	10	267.2
3	126	11	323.4
4	168	12	384.8

Armstrong Magnetics Inc
700 Sunset Pond Ln., #4
Bellingham, WA 98226
Toll Free: 1 800 965 4968
Tel: 360 647 8438
Fax: 360 539 1850
Email: sales@armsmag.com
Web: www.armsmag.com

Copyright © 2011 Armstrong Magnetics – All Rights Reserved.
